

CABLE TRAYS – CONNECTION INSTRUCTIONS

Introduction

The purpose of this document is to describe the correct process to install the connectors in our cable trays.

It is possible to use cable trays as grounding conductor equipment. In accordance with National Electrical Code (NEC) Article 392 “**Cable trays**” first determine the Maximum Fuse Ampere Rating or Circuit Breaker Ampere Trip Setting or Circuit Breaker Protective Relay Ampere Trip Setting for Ground-Fault Protection being used in the Cable Tray System.

Once this is determined, refer to **Table 392.60A (Metal Area Requirements for cable trays used as Equipment Grounding Conductor)** to see if the cable tray system you are installing meets the minimum cross-sectional area. If the cable tray system you are installing does not meet the minimum cross-sectional area for the maximum Ampere Rating, refer to **Table 250.122 (minimum size equipment grounding conductors for grounding raceway and equipment)** to determine the minimum size equipment grounding conductor needed to be installed within the entire cable tray system to be in compliance with the NEC.

Note: Each cable tray section and fitting must be bonded to the additional equipment grounding conductor assembly installed.

Cat. Nos.	No. of Wire/ diameter, mm	Cross-sectional areas, mm ² / in. ²	Cat. Nos.	No. of Wire/ diameter, mm	Cross-sectional areas, mm ² / in. ²
446W6295P001	10 / 4.5 mm	159.09 mm ²	446W6295P019	10 / 4.5 mm	159.09 mm ²
446W6295P002			446W6295P020		
446W6295P003			446W6295P021		
446W6295P004			446W6295P022		
446W6295P005			446W6295P023		
446W6295P006			446W6295P024		
446W6295P007			446W6295P025		
446W6295P008			446W6295P026		
446W6295P009			446W6295P027		
446W6295P010			446W6295P028		
446W6295P011			446W6295P029		
446W6295P012			446W6295P030		
446W6295P013			446W6295P031		
446W6295P014			446W6295P032		
446W6295P015			446W6295P033		
446W6295P016			446W6295P034		
446W6295P017			446W6295P035		
446W6295P018					



Minimum Size Equipment Grounding Conductors for Grounding Raceway and Equipment.

Table 250.122; Minimum size Equipment Grounding Conductors for Grounding Raceway and Equipment		
Rating or Setting of Automatic Overcurrent Device in Circuit Ahead of Equipment, Conduit, etc., Not Exceeding (Amperes)	Size (AWG or kcmil)	
	Copper	Aluminum or Copper-Clad Aluminum
15	14	12
20	12	10
60	10	8
100	8	6
200	6	4
300	4	2
400	3	1
500	2	1/0
600	1	2/0
800	1/0	3/0
1000	2/0	4/0
1200	3/0	250
1600	4/0	350
2000	250	600
2500	350	600
3000	400	600
4000	500	750
5000	700	1200
6000	800	1200

Note: where necessary to comply with 250.4(A)(5) or (B)(4), the equipment grounding conductor shall be sized larger than given in this table.



Metal area requirements for cable trays used as equipment grounding conductor.

Maximum Fuse Ampere Rating, Circuit Breaker Ampere Trip Setting, or Circuit Breaker Protective Relay Ampere Trip Setting for Ground-Fault Protection of Any Cable Circuit in the Cable Tray System	Minimum Cross-Sectional Area of Metal			
	Steel Cable Trays		Aluminum Cable Trays	
	mm ²	in. ²	mm ²	in. ²
60	129	0.20	129	0.20
100	258	0.40	129	0.20
200	451.5	0.70	129	0.20
400	645	1.00	258	0.40
600	967.5	1.50	258	0.40
1000	--		378	0.60
1200	--		645	1.00
1600	--		967.5	1.50
2000	--		1290	2.00

* Total cross-sectional area of both side rails for ladder or trough cable trays; or the minimum cross-sectional area of metal in channel cable trays or cable trays of one-piece construction.

** Steel cable trays shall not be used as equipment grounding conductors for circuits with ground-fault protection above 600 Amperes. Aluminum cable trays shall not be used as equipment grounding conductors for circuits with ground-fault protection above 2000 amperes.



Material Required

For each end being connected it will be required:

- 2 x Steel lock nut ISO7042 M8x1.25mm
- 2 x Round head square neck bolt DIN 603 M8x25
- 2 x Heavy duty structural plain washer DIN7349 M8
- 1 x Clamping bracket

Connection Instructions

On the desired location, position the chosen connecting bracket and clamp it using the fasteners above. There is a variety of connecting brackets available to cover different purposes, thus they will have different designs depending on the usage.

The positioned clamping plate can be seen on Figure 1

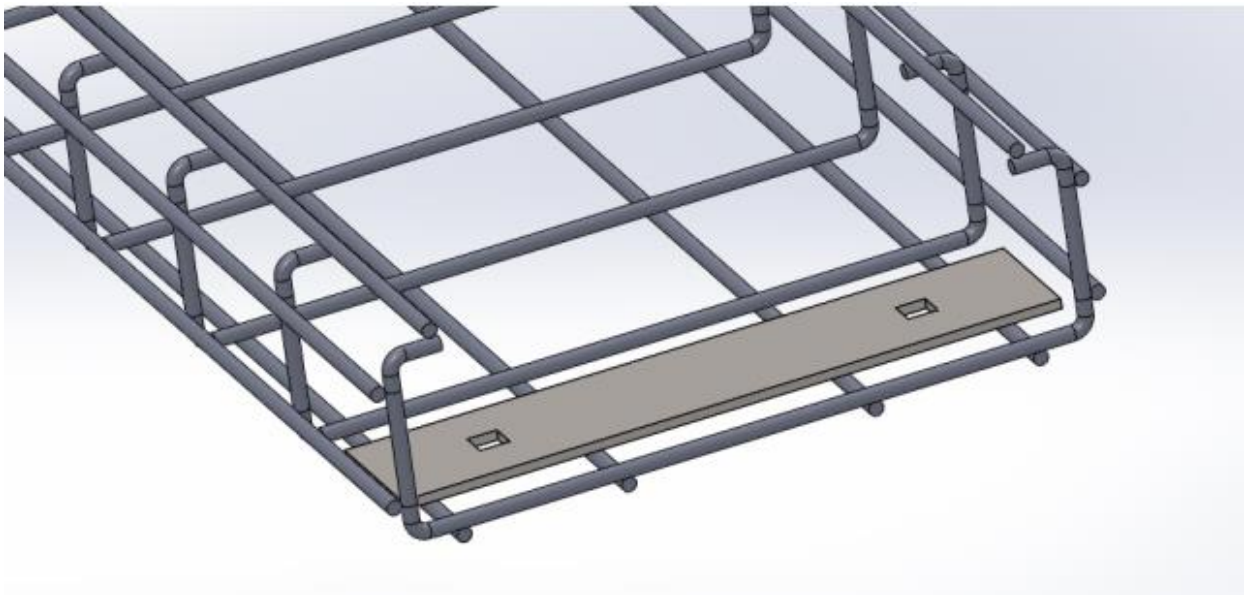

Figure 1- Clamping bracket positioned



Assembly

1. Place clamping brackets inside the tray
2. Place bolts in the square hole of the bracket, all bolt heads must be placed inside the trays, to prevent damage to the cable insulation.
3. All nuts must be tightened securely with appropriate tools

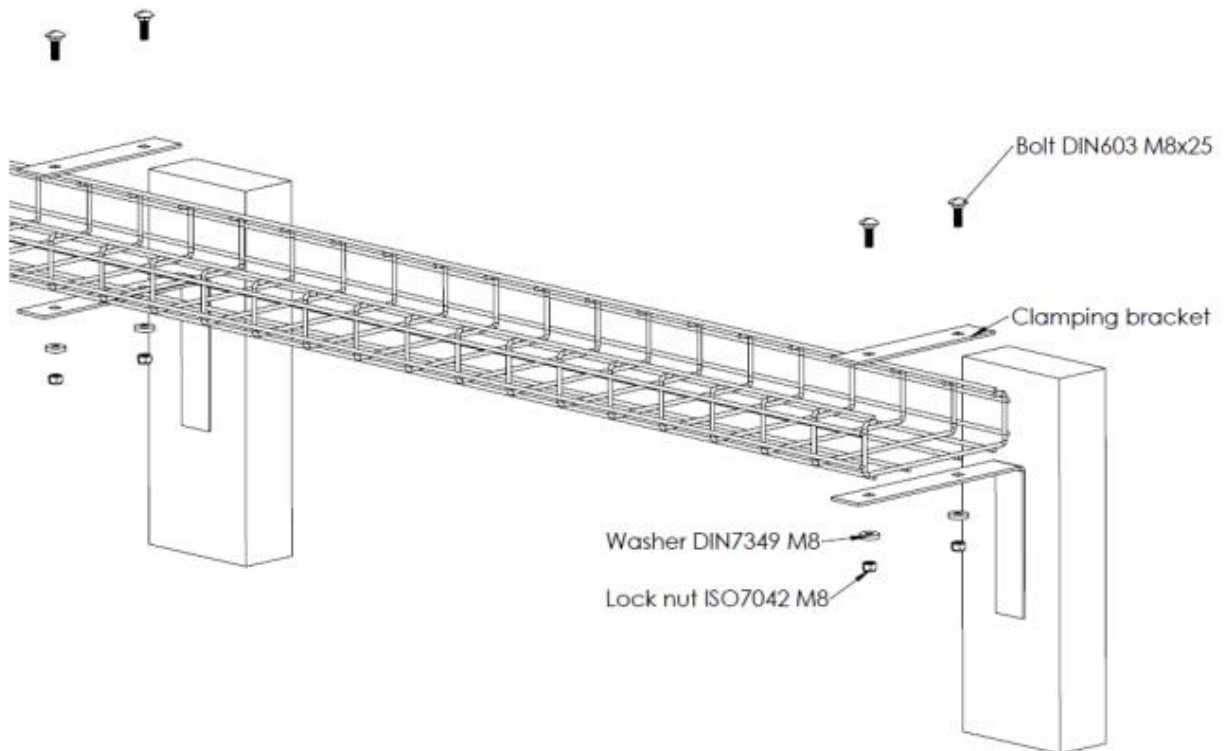

Figure 2 - Clamping to wall brackets



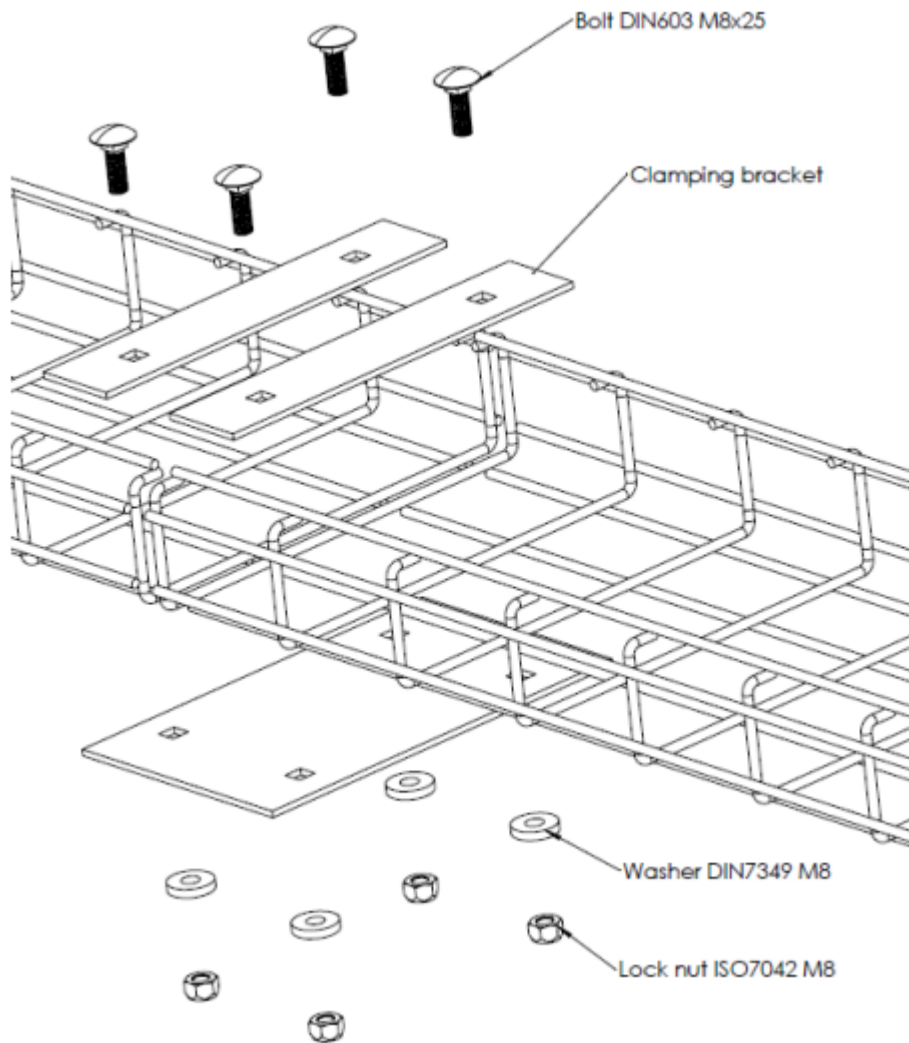

Figure 3- Clamping two trays together



Resolux contact information:

Web: www.resoluxgroup.com

Email: quality@resoluxgroup.com

/June 2024

